

Untersuchung thermoakustischer Oszillationen mittels Laservibrometer

Laser Vibrometry for Combustion Diagnostics in Thermoacoustic Research

J. Peterleithner, J. Woisetschläger

Institut für Thermische Turbomaschinen und Maschinendynamik, Technische Universität Graz
Inffeldgasse 25A, 8010 Graz, Österreich

Korrespondierender Autor: jakob.woisetschlaeger@tugraz.at

Schlagworte: Interferometrie, Laser Vibrometer, Thermoakustik, Verbrennungsdiagnostik
Key words: Interferometry, Laser Vibrometry, Thermoacoustics, Combustion Diagnostics

Zusammenfassung

In einem Projekt der Technischen Universität Graz, welches durch den österreichischen Wissenschaftsfond FWF gefördert wird, wurde nachgewiesen, dass sogenannte Laser-Vibrometer – Interferometer die in den Ingenieurwissenschaften zur Messung von Oberflächenschwingungen zum Einsatz kommen – die zeitliche Ableitung der Dichteschwankungen und somit Schwankungen der Wärmefreisetzung in Flammen direkt messen können. Der gleichzeitige Einsatz mehrerer solcher Geräte erlaubt sowohl die globale als auch lokale Bestimmung dieser wichtigen Größe, als auch die Bestimmung gemittelter Geschwindigkeiten innerhalb des Strömungsfeldes. Hierzu wurde eine drallstabilisierte, abgehobene Methanflamme mit und ohne Brennkammer mit verschiedenen optischen Methoden untersucht, um die Aussagekraft dieser neuen Messmethode zu überprüfen. Zusätzlich kann es bei dieser Flamme in einer Modellbrennkammer zu thermoakustischen Oszillationen um 200Hz.

Abstract

Within a project at Graz University of Technology, funded by the Austrian Science Fund (FWF) we demonstrated that so-called laser vibrometers – usually used to record surface vibrations - record the time derivative of density fluctuations and thus the heat release rate in flames directly. The simultaneous use of several of such systems enables global and local recording of this important number, as well as, the average velocity in such flow fields. To test the significance of these findings, a swirl-stabilized lifted methane flame was investigated with different optical measurement techniques. Using this flame in a model combustor a thermoacoustic oscillation at app. 200 Hz was excited.

Introduction

State-of-the-art technology in industrial gas turbines for power generation uses lean pre-mixed combustion for high combustion efficiency and low emissions. High power densities and lean combustion increase the susceptibility to thermoacoustic oscillations. These instabilities arise from the positive coupling between the fluctuations of pressure and heat release (Rayleigh 1878). The Institute for Thermal Turbomachinery and Machine Dynamics, Graz

University of Technology, is specialised in research and education in the field of turbomachinery and their application in modern power plants, airplanes and vehicles. This research is supported by large experimental facilities, including a 3 MW compressor station and a 5 MW thermal air heater supplying hot compressed air to several test rigs, e.g. a small model combustion chamber (currently up to 5 bar and 50 kW methane or kerosene flames).

Background

Laser vibrometers (LV) are interferometric systems widely used to detect surface vibrations from machinery. With an acoustic-optical modulator as frequency modulator, these interferometers record vibration velocity rather than vibration amplitude. In combustion research at TU Graz these systems are used to detect density fluctuations with fixed geometry in the optical path because LV directly record the time derivative of density (Giuliani et al. 2010, Köberl et al. 2010, Leitgeb et al. 2013, Fischer et al. 2013, Peterleithner et al. 2015b). The changes in density occur through changes of pressure p or entropy s (Dowling and Morgans 2005, Joos 2006):

$$\frac{d\rho}{dt} = \frac{1}{c^2} \frac{dp}{dt} - \frac{(\kappa-1)}{c^2} \dot{q}_v \quad , \quad \text{eq. (1)}$$

with \dot{q}_v the heat release rate per unit volume, p pressure, c the speed of sound, κ the ratio of the specific heat capacities and t time. It can be shown that the pressure term can be neglected in flames, because it is at least an order of magnitude smaller than the other terms in equation (1) (Dowling 1995, Dowling and Morgans 2005). This proportionality between the time derivatives of density recorded by LV and the desired heat release rate in the flame front was shown by Leitgeb et al. 2013. While all other techniques exhibit problems in the determination of local heat release rates (see Lauer 2011), LV can be used to provide heat release rates \dot{Q} within the entire combustion volume, or local \dot{q} . While interferometric line-of-sight data need tomographic reconstruction to obtain local values – or Abel-Inversion in case of objects with cylindrical symmetry - dual-LV techniques provide these local data in one recording (Hampel et al. 2006, Peterleithner et al. 2014).

In aero-acoustics without flame LV are used to characterize the pressure field (sound field). In such applications only the first term in equation (1) is of interest (Mayrhofer et al. 2000, Zipser et al. 2002, Woisetschläger et al. 2003, Buick et al. 2004, Gren et al. 2006, Martelli et al. 2013).

The time derivatives in equation (1) express the contributions of pressure and heat release to the density fluctuations recorded. Using Reynold's definition of mean and fluctuating components and replacing the materials derivatives in equation (1) by partial derivatives, convective terms will appear. These convective terms include density gradients and velocities, as well as, the respective fluctuating components. With velocities and velocity fluctuation small compared to the speed of sound (low Mach number problems) the convective transport of heat release fluctuations is small in equation (1). Neglecting all these small contributions and under the assumption that the LV records data only in the flame where pressure fluctuations can be neglected and that the recording is not done at a combustion chamber resonance frequency we get

$$\frac{\partial \rho'}{\partial t} = - \frac{(\kappa-1)}{c^2} \frac{\partial \dot{q}'_v}{\partial t} \quad , \quad \text{eq. (2)}$$

with the dash denoting the fluctuating component. (see Peterleithner et al. 2015a for a more detailed discussion). While in low Mach number problems the contributions of the convective terms to the signal amplitudes are small, these convective terms do influence the phase.

First studies revealed that two LV with parallel beams or crossed beams can record flow velocities in flames using the phase lag whenever a density structure first passes through beam 1, then through beam 2 (Köberl et al. 2010, Peterleithner et al 2014).

Experimental Setup: The Methane/Air Burner

This work and previous work (Giuliani et al. 2012, Fischer et al., 2013;) used a variable-geometry premixed swirl-stabilised Methane/air burner at atmospheric pressure conditions. A variable nozzle geometry alters the flame in terms of rotation or swirl of the fluid and the exit area ratio of the exit nozzle. The rich-lean variable geometry burner used in this investigation is seen in figure (1) with the most important parts. The centre body is moved in axial direction, varying the exit area, while the swirl strength is set by the ratio between axial and tangential air, while keeping the overall air- and Methane-flows constant. In order to investigate thermo-acoustic oscillations in a combustion chamber, the burner was combined with in an optically accessible liner at atmospheric pressure. In figure (1) the schematics of the burner are shown together with a schlieren visualisation on the left side of the image and the spectral emittance at 430nm (CH*) on the right side. Both schlieren visualisation and chemiluminescence are line-of sight data. For schlieren visualisation 700 frames were recorded with $f=2032\text{mm}$, 280mm diameter parabolic mirrors for the schlieren setup, and a 3CCD camera (NV-DX100EG, Panasonic, Osaka, Japan) at full aperture, 1/8000s, 0dB. These 700 recordings were used for the average process including only the 10% brightest pixels. Such procedure produces streamlines around the combustion zone and shows small turbulent combustion structures. OH* and CH* line-of-sight time-averaged chemiluminescence was recorded using TECHSPEC Bandpassfilter 310nm was used for the OH* emission and a TECHSPEC Bandpassfilter 430nm for the CH* emission (both Edmund Optics, Barrington, NJ, USA) together with an ICCD camera (NanoStar, 1280x1024pixel, LaVision, Göttingen, Germany) and a UV lens (105mm, f/4.5, Nikon, Tokio, Japan). All systems were carefully calibrated using neutral density filters for visible (MGA, Melles Griot Inc., CA, USA) and UV (fused silica NDUV, UV Metallic ND, Thorlabs, NJ, USA). background images were always recorded and subtracted. For the results shown in this publication, the burner was operated at 3.37kW

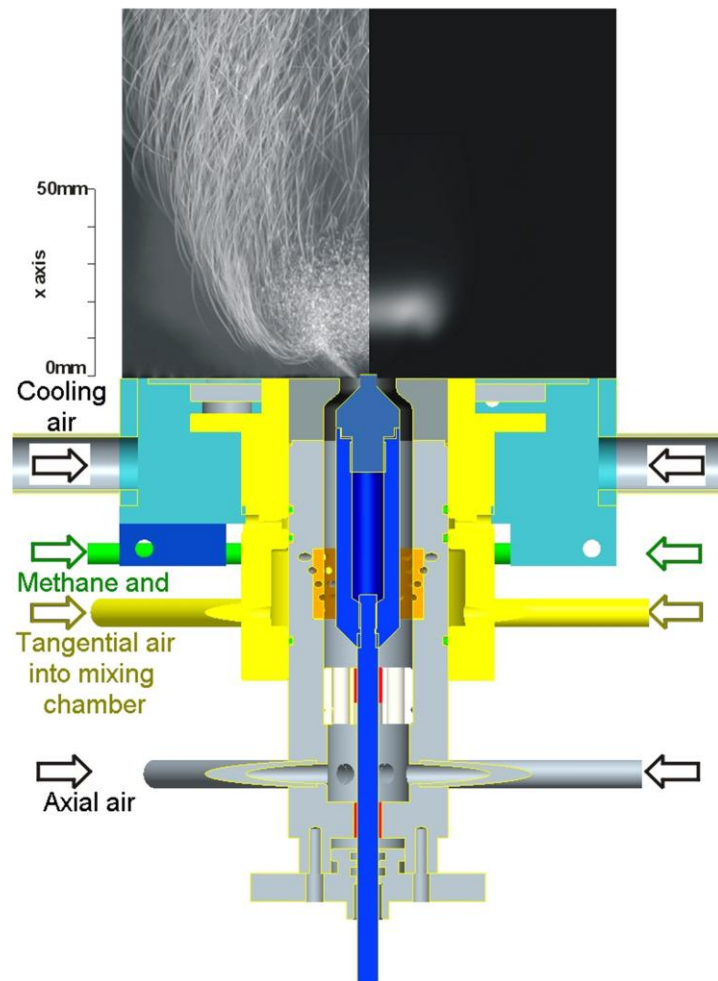

Fig. 1: Variable geometry burner used to record thermo-acoustic oscillations in a swirl-stabilized Methane flame

power, $0.9 \dot{m}_{tan} / \dot{m}_{ax}$ (tangential to axial mass flows), a global equivalence ratio of 0.68, and a swirl number of 0.65. The equivalence ratio is used to discuss the combustion and is the ratio of the oxygen-fuel ratio and the stoichiometric oxygen-fuel ratio, with lean mixtures <1 .

Experimental Setup: The Laser Vibrometer

For the investigations two laser vibrometers were used (interferometer head OFV-353, velocity decoder OFV-3001, calibration factor 5mm/s/V, 20kHz bandwidth, no filters, Polytec, Waldbronn, Germany). The basic setup is shown in figure (2). A -40mm lens was used to collimate the beam to 1.5-2mm diameter. To scan the field, the combustor was mounted on a DANTEC lightweight traverse (DANTEC Dynamics, Roskilde, Denmark), while the vibrometer was fixed. Analog input modules NI-91215 (National Instruments, Austin, Texas) and Labview 8.6 software were used for data recording. Each scanned position was sampled with 245760 samples at a sample rate of 4096S/s. Together with the vibrometer voltage a microphone signal was recorded (KECG2738PBJ-A, miniature electret condenser microphone, omni-directional, -40dB, 2.8mm diameter, Kingstate Electronics Corp, New Taipei City, Taiwan). This type of laser vibrometer uses a Bragg cell to record velocities rather than amplitudes. For the phase shift $\varphi(t)$ between reference and object wave (and thus the optical path difference ΔL) we find

$$\frac{\partial}{\partial t} \varphi(t) = \frac{2\pi}{\lambda} \frac{\partial}{\partial t} \Delta L(t) = \frac{2\pi}{\lambda} G \int_z \frac{\partial \rho'(z,t)}{\partial t} dz = \frac{2\pi}{\lambda} k_{vib} U(t) \quad \text{eq. (3)}$$

using G the Gladstone-Dale constant for the given equivalence ratio (Gardiner et al. 1981), $\rho'(z,t)$ the density fluctuations along the optical axis, k_{vib} the calibration constant of the vibrometer, here 5mm/s/V, and $U(t)$ the vibrometer output voltage. z is the coordinate along the optical axis of the LV. The integral expresses the line-of-sight character of the measurement. Recording frequency spectra or power spectra $S(f)$ by a Fast-Fourier-Transform FT the time derivative of density fluctuations along the beam path can be transformed into the density fluctuation by using the $2\pi f$ conversion factor at the given frequencies f :

$$S(f) = FT^2 \left[\int \rho'(t) dz \right] = \frac{1}{4\pi^2 f^2} FT^2 \left[\int \frac{\partial \rho'}{\partial t}(t) dz \right] = \frac{1}{4\pi^2 f^2} FT^2 \left[\frac{k_{vib} U(t)}{G} \right] \quad \text{eq. (4)}$$

After calculation of power and amplitude spectra the resultant number is a RMS value. To obtain the amplitude at a given frequency a factor of $\sqrt{2}$ must be considered. This was done for all results presented in the next sections.

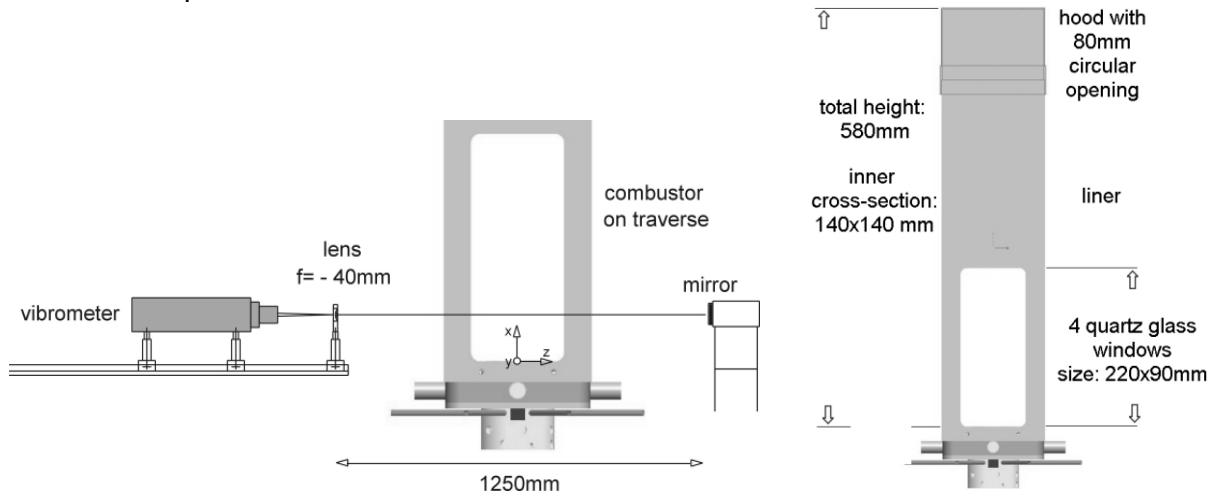

Fig. 2: Setup of the laser vibrometer (left) and details of the liner used on top of the burner

When two laser vibrometers are used, local density fluctuations can be recorded by correlating signals from the two intersecting laser beams (Hampel et al. 2006). For this dual laser vibrometry either one, or both vibrometers can be traversed horizontally, or the burner is traversed in order to get radial profiles of density fluctuations at certain frequencies or frequency bands with the vibrometers fixed. Another possibility is to scan the flow in axial direction with only one laser vibrometer, while the second vibrometer and the burner are fixed. When in a flame, a density fluctuation now firstly crosses laser beam 1, secondly beam 2, a phase delay is recorded, depending on the convective flow velocity of this structure in axial direction. Whenever such a structure decays while moving in axial direction, or leaves the test volume due to tangential motion, the correlation will be lost. This will provide information on structural decay and velocity. The cross-correlation $C(f)$ is calculated from the two laser vibrometer frequency spectra $F_1(f)$ and $F_2(f)$ by

$$\overline{C(f)} = \overline{F_1(f) \cdot F_2^*(f)} \quad \text{eq. (5)}$$

Due to the turbulent nature of combustion, a high number of single spectra must be averaged to obtain meaningful results.

Results and Discussion

In this model combustor thermo-acoustic oscillations have been observed and documented in earlier works (Peterleithner et al. 2014, Peterleithner et al. 2015b). While it was assumed first that the liner closed the feedback loop – meaning that a liner is necessary to form a cavity resonance – it turned out that the instability occurs even without liner. But, the liner amplifies this instability. Figure (3) shows the resultant frequency spectra of a line scan through the flame with and without liner at different heights. These frequency spectra show very similar features. When discussing the spectra of the flame without liner first, we observe a periodic phenomenon at 230Hz with a higher harmonic at 460Hz, suggesting a non-sinusoidal signal. Such instabilities in a burner have recently been discussed by Emmert et al 2015. With the liner in place the signal increases and an additional acoustic wave is excited at a frequency of 200Hz, easily detectable at the distinctive peak in the spectrum shown in the middle image in figure (3). Now the periodic instability from the burner excites a standing wave in the combustor. Strong amplitudes can be seen in the flame and lower amplitudes in the non-reacting areas outside the flame. It is important to learn that the pressure term in equation (1) can not necessarily be neglected when a combustion chamber resonance is observed. When the line scan is performed above the combustion zone, as shown in the right plot in figure (3), the amplitude at the chamber resonance frequency has its maximum beyond a radial extend of 20mm. Comparing this finding with the schlieren image in figure (1) one finds that in this region mixing with colder air take place. While in the center the hot gases from the combustion flow downstream, the colder cooling gases in the outside seem to have just the correct temperature to particularly enable the standing wave, thus the higher resonance amplitude in this region. In the scans at 40mm height (figure 3, right plot) strong amplitudes were detected at the lower frequencies at 15Hz and at 30Hz across the whole section of the burner. The 30Hz signal is constant at all positions scanned, indicating a structural vibration of the test rig. This frequency has been identified as the flexural mode of the burner mounted on the traverse (see Peterleithner et al. 2014). In contrast, the 15Hz frequency is not of uniform amplitude along the cross-section of the combustion chamber and slowly decays towards higher frequencies, indicating a convective-aerodynamic effect. In this region hot strains from the flame rise next to cooling air along the windows. This convective transport of heat was already expected by analyzing the Schlieren image.

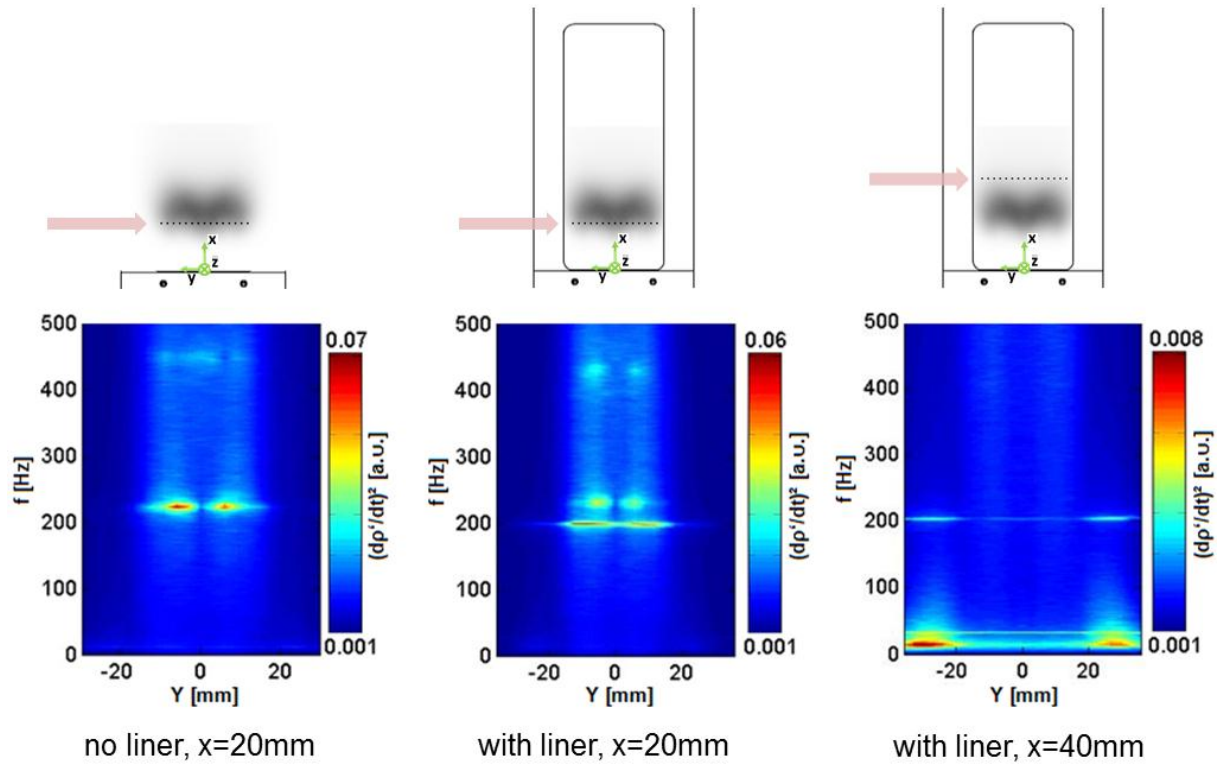

Fig. 3: Frequency spectra when a laser vibrometer beam is scanned through the flame at resonant conditions using the laser vibrometer at two different heights with and without liner.

With two LV it is possibility is to scan the flow in axial direction with only one laser vibrometer, while the second vibrometer and the burner are fixed. When a density fluctuation now crosses laser beam 1 first, then beam 2, a phase delay is recorded, depending on the axial velocity of this structure. Whenever such a structure decays while moving in axial direction, or leaves the test volume due to tangential motion, the correlation will be lost. Such a scan for density fluctuations for two LV with perpendicular laser beams is shown in figure(4) for frequencies between 0 and 180Hz with a cavity resonance at 165Hz. Seen is the phase lag observed while scanning one LV, while the other is fixed. The data reduction was done according to equation (5) by a cross-correlation procedure with a high number of samples due to the high level of turbulence in this flow. Starting height was at $x=120\text{mm}$ above the burner nozzle. At this position one LV was fixed while the other LV traversed in axial direction up to a height of 180mm. In the lower frequency range the convective heat transport is observed, also visible in the schlieren image in figure (1). From the phase lag $\Delta\varphi(x)$ in x -direction, the known scanning distance Δx , and the frequency f , the axial velocity v_{ax} can be obtained.

$$v_{ax} = \frac{2\pi}{\Delta\varphi(x)} \cdot \Delta x \cdot f \quad \text{eq. (6)}$$

This procedure resulted in a axial velocity of 2.5m/s, which is in good agreement with laser-optical velocity measurements performed in this setup (Peterleithner et al. 2015b). At higher frequencies a loss of coherence between the two LV signal is observed, due to a structural decay at these frequencies. This decay can also be seen from the correlation amplitude spectra not presented here. Another possibility for this loss of coherence is the strong tangential movement in this swirl-stabilized flame. At about 165Hz the field is dominated by the thermo-acoustic oscillation. No significant phase delay between the LV positions can be observed at this frequency due to the high speed of sound. In equation (1) the pressure term

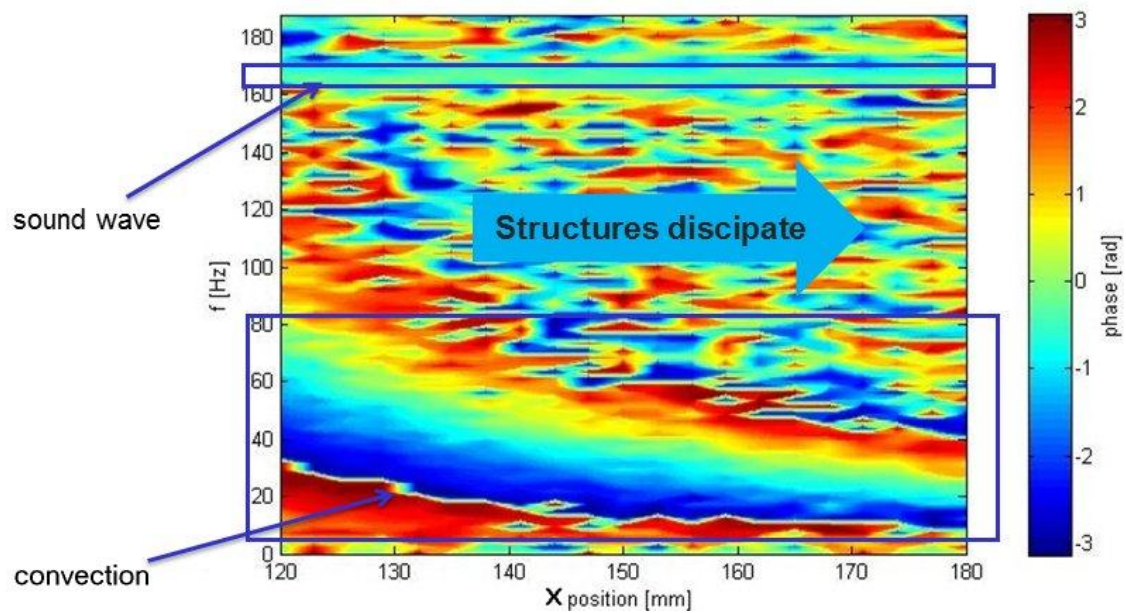

Fig. 4: Recording the velocity of the convective heat transport by using phase correlation from dual laser vibrometry.

cannot be longer neglected at this frequency, meaning that the sound wave (pressure wave) dominates the phase in this spatio-temporal correlation at 165Hz.

Summary and Outlook

When using laser vibrometers for combustion diagnostics based on equations (1)-(6) amplitude and phase of density-fluctuation frequency-spectra can be recorded. These spectra can then be used to classify the flame and discuss thermo-acoustic oscillations. Quantitative data depend on the the Gladstone-Dale constant, which has to be calculated from local equivalence ratios, e.g. by OH^*/CH^* ratios (see Peterleithner et al. 2014), and depend on the speed of sound, for which local temperatures must be estimated. For further flame characterization, flame transfer functions (FTF) correlate the relative heat release rate fluctuations (\dot{Q}'/\bar{Q}) and the relative velocity fluctuations (v'/\bar{v}) at the burner outlet. Principally all these numbers can be detected by LV. Peterleithner et al. 2015a showed recently that the fluctuations in global heat release rate \dot{Q}' recorded in perfectly premixed flame do agree between LV recorded data and data recorded by OH^* -chemiluminescence. Data from measurements using a high number of LV beams, maybe even from multiple directions, could provide local spatio-temporal correlations. This would also be helpful for quantitative recording of density fluctuations.

Acknowledgements

This research was funded by the Austrian Science Fund FWF within grant FWF-24096-N24 "Interferometric Detection of Thermoacoustic Oscillations in Flames". The authors would like to thank Dr. Andreas Marn for his kind support and the ongoing discussion on acoustics.

References

- Buick, J.M., Cosgrove, J.A., Douissard, P.A., Greated, C.A., Gilibert, B., 2004: "Application of the acousto-optic effect to pressure measurements in ultrasound fields in water using a laser vibrometer", *Rev. Sci. Instrum.* [75:3203–3207](#)
- Dowling A.P., 1995: "The Calculation of Thermo-acoustic Oscillations", *Journal of Sound and Vibration*, [180\(4\): 557–581](#).
- Dowling, A.P., Morgans A.S., 2005: "Feedback control of combustion oscillations", *Annu. Rev. Fluid Mech.*, [37: 151-182](#)
- Emmert, T., Bomberg, S., Polifke, W., 2015: „Intrinsic thermoacoustic instability of premixed flames“ *Combustion and Flame*, [162:75-85](#)
- Fischer, A., König, J., Czarske, J., Peterleithner, J., Woisetschläger, J., Leitgeb, T., 2013: "Analysis of flow and density oscillations in a swirl-stabilised flame employing highly resolving optical measurement techniques", *Experiments in Fluids*, [54:1622 \(18pp\)](#)
- Gardiner WC, Hidaka Y Jr., Tanzawa T (1981) Refractivity of combustion gases, *Combustion and Flame* [40:213-219](#)
- Giuliani, F., Leitgeb, T., Lang, A., Woisetschläger, J., 2010: Mapping the density fluctuations in a pulsed air-methane flame using laser-vibrometry", *ASME J. Eng. Gas Turbines Power*, [132:031603](#)
- Giuliani, F., Woisetschläger, J., Leitgeb, T. 2012: "Design and validation of a burner with variable geometry for extended combustion range", *Proceedings of ASME Turbo Expo 2012, GT2012*, June 11-15, 2012, Copenhagen, Denmark, [GT2012-68236](#)
- Gren, P., Tatar, K., Granström, J., Molin, N.E., Jansson E.V., 2006: "Laser vibrometry measurements of vibration and sound fields of a bowed violin", *Meas. Sci. Technol.*, [17:635–644](#)
- Hampel, B., Woisetschläger, J., 2006: "Frequency- and space-resolved measurement of local density fluctuations in air by laser vibrometry", *Meas. Sci. Technol.*, [17:2835–42](#)
- Harland, A.R., Petzing, J.N., Tyrer, J.R., Bickley, C.J., Robinson S.P., Preston, R.C., 2003: "Application and assessment of laser Doppler velocimetry for underwater acoustic measurements", *J. Sound & Vibration* [265:627–645](#)
- Joos, F., 2006: „Technische Verbrennung, Verbrennungstechnik, Verbrennungsmodellierung“, Springer-Verlag, Berlin, Heidelberg, 1st edition, [ISBN -10 3-540-34333-4](#)
- Köberl, S., Fontaneto, F., Giuliani, F., Woisetschläger, J., 2010: "Frequency resolved interferometric measurement of local density fluctuations for turbulent combustion analysis", *Meas. Sci. Technol.*, [21:035302 \(10pp\)](#)
- Lauer M.R.W., 2011: "Determination of the Heat Release Distribution in Turbulent Flames by Chemiluminescence Imaging", Dissertation, [Technische Universität München](#)
- Leitgeb, T., Schuller, T., Durox, D., Giuliani, F., Köberl, S., Woisetschläger, J., 2013: "Interferometric determination of heat release rate in a pulsated flame", *Combustion and Flame* [160:589–600](#)
- Martarelli, M., Castellini, P., Tomasini E.P., 2013: "Subsonic jet pressure fluctuation characterization by tomographic laser interferometry", *Experiments in Fluids*, [54:1626 \(pp13\)](#)
- Mayrhofer, N., Lang, H., Woisetschläger, J., 2000: Experimental Investigation of Turbine Wake Flow by Interferometrically Triggered LDV-Measurements, *Proc. 10th International Symposium on Application of Laser Techniques to Fluid Mechanics*, Lisbon, [paper 28.1](#)
- Peterleithner, J., Salcher, F., Woisetschläger, J. 2014: "Frequency resolved interferometric detection of local density fluctuations in flames", *Proc. 17th International Symposium on Application of Laser Techniques to Fluid Mechanics*, Lisbon, [paper 04.7 1 53](#)
- Peterleithner, J., Stadlmair, N.V., Woisetschläger, J., Sattelmayer, T., 2015a: "Analysis of measured flame transfer functions with locally resolved density fluctuations and OH-chemiluminescence data" *Proceedings of the ASME Turbo Expo 2015: GT2015*, June 15-19, 2015, Montréal, Canada, [GT2015-42745](#)
- Peterleithner, J., Marn, A., Woisetschläger, J., 2015b: "Interferometric Investigation of the thermoacoustics in a swirl stabilized Methane flame" *Proceedings of the ASME Turbo Expo 2015: GT2015*, June 15-19, 2015, Montréal, Canada, [GT2015-42743](#)
- Rayleigh, J.W.S., 1878: "The Explanation of Certain Acoustical Phenomena" *Nature*, [18\(4\): 319–321](#).
- Woisetschläger, J., Mayrhofer, N., Hampel, B., Lang, H., Sanz, W., 2003: "Laser-optical investigation of turbine wake flow", *Exp.Fluids*, [34:371-378](#)
- Zipser, L., Lindner, S., Behrendt, R., 2002: „Interferometrische Messung und Visualisierung von Schallwellen und Turbulenzen“, *Tech. Mess.* [6: 275–81](#)